

SPECIFICATION

MEASUREMENT	METHOD / INSTRUMENT
WEIGHT	Digital scale Axis (precision 0,01g)
HEIGHT	Gawis-OD Agr / Electronic altimeter (precision 0,01mm)
TOP LOAD	Top Load Agr / Digital Newton meter BFG N (0,1-500N)
DIAMETER	Gawis-OD Agr / Micrometer of 0,001mm precision, according to DIN 863
COMPONENTS	Gawis-OD Agr / Digital caliper of 0,01mm precision, according to DIN 862
MATERIAL DISTRIBUTION	Gawis-OD Agr / PTG5004 AGR
TOTAL CAPACITY AND FILLING HEIGHT	Combi Agr
HORIZONTAL AND VERTICAL ALIGNMENT	Gawis-OD Agr / Angle gauge, according to DIN 875/0 + Gap gauge (0,05-1,0mm) (max. 1,0mm/100mm)
STABILITY ON THE SURFACE	Flat marble slab + Gap gauge (0,05-1,0mm)
COLOUR	Spectrophotometer Ci5 (laser measurement) according to standard
DROP TEST	Trap on 1,5m height
TIGHTNESS	Vacuum chamber (underpressure of 600mbar during 180s.)
PRODUCT IMPLEMENTATIONS AND QUALITY ANALYSIS ARE PERFORMED WITH THE USE OF THE FOLLOWING DEVICES: Agr Gawis-OD, Top Load/Combi, PTG5004	

TECHNICAL DRAWING

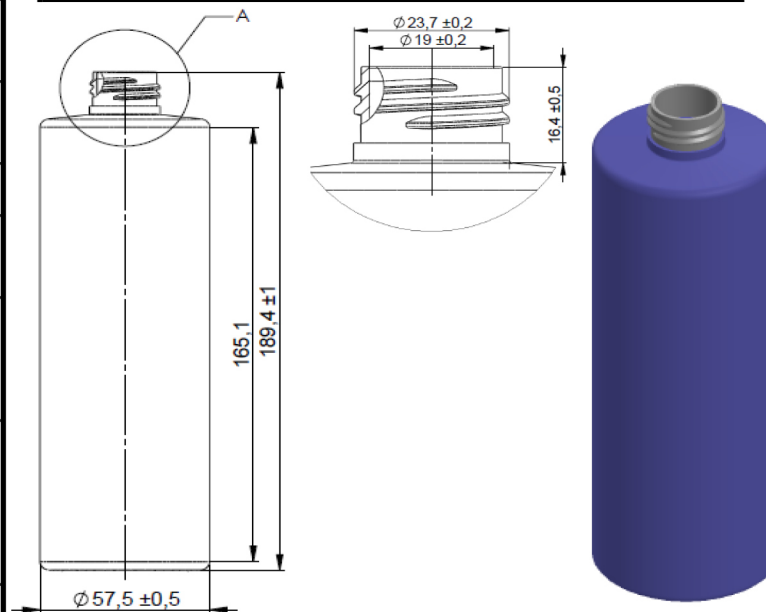

Capacity:	400,0 ml
Thread:	24-410
Material:	polyethylene terephthalate

Parameters	Given dimensions	Tolerance
Height (mm)	189,40	+/- 1,0
Base diameter (mm)	57,50	+/- 0,5
Weight (gr)	26,00	+/- 1,0
Total capacity (ml)	430,00	+/- 9,0
Distance to the cap (mm)	16,40	+/- 0,5
Outer diameter thread with a roll (mm)	23,70	+/- 0,2
Inner diameter of the hole (mm)	19,00	+/- 0,2
VERTICAL (max 1/100mm)	V	-
IT SHRINKS ON SURFACE SECONDARY	X	-
SHAPE CONFORMITY	V	-
STABILITY BASE BOTTLE	V	-

PACKAGING

PALLET APPEARANCE	LAYOUT ON THE LAYER
-------------------	---------------------

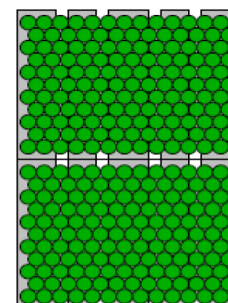
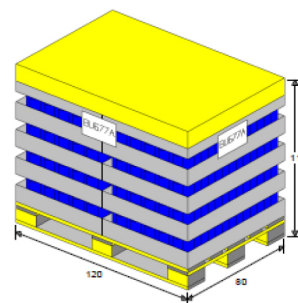

ON PALLET	1430
LAYERS	5
ON LAYER	2 x 143 (286pcs)
PALLET HEIGHT (mm)	1110,00 mm

STORAGE CONDITIONS

Product should be stored in clean, dry, airy condition. Keep in temperature between -10° do 40°C and humidity 0-90% . Products must to be protected against the harmful effects of radiant heat or direct sunlight. Do not stored in open landfills. Product packaging must be clean, dry and free of odors.